

TELEPHONES LE LAS (FRANCE Head Office)

Tel:0033 1 48766262

E-mail: lelas@lelas.fr

Fax:0033 1 48768304

Web-site:www.lelas.fr

All screws are stainless-steel only

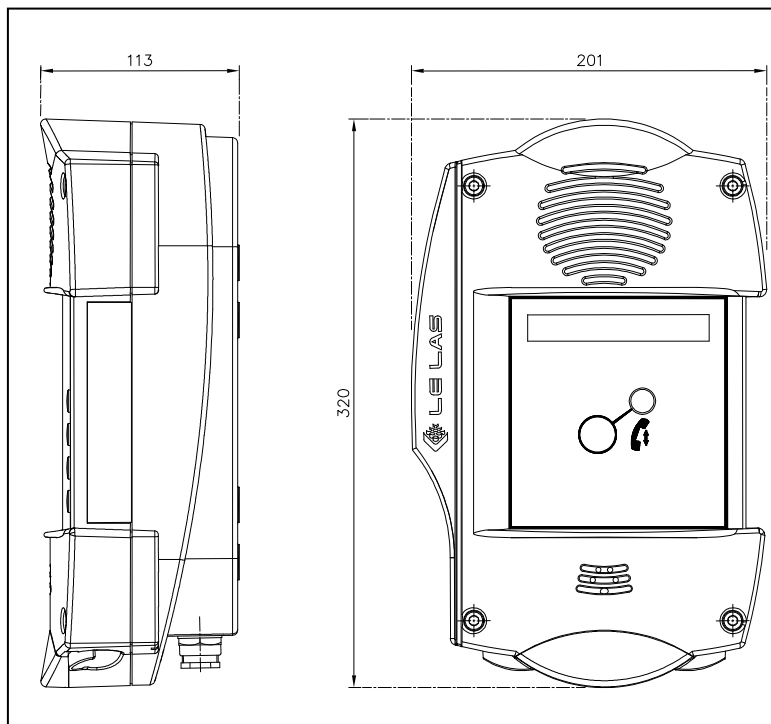

Body material / Color:.....Polyester plastic / RAL2003
 Loudspeaker/microphone:vandal resistant
 Mounting:on wall
 Termination:Inside screw connections
 Dimensions: 201 X 320 X 113 mm
 Weight:2,0 kg
 IP-rating:.....IP66
 Max. / min. amb. Temp:.....-40 °C / + 60°C
 Maintenance:

all circuits and control devices are fixed on the easy removable front plate for a very quick substitution of equipment in field

Available Versions:

TLS402E2C1F : with integrated flashing beacon

TLS402E2C2: with 2 call buttons

TLS402E2C9FG : with integrated flashing beacon and keypad

Installation, Operation and Maintenance Procedures

- Open the pivoting front panel removing the three screws.
- Pass the cables through the cablelands being sure that the cable fit with the rubber gasket
- Connect the telephone wires at the screw terminals as indicated in the operator's book
- Make a functional test calling another extension and asking to be re-called
- Adjust the volume of the bell (see operator's book)
- Adjust the sensitivity of the microphone (see operator's book)
- Close the front panel paying attention to the position of the gaskets

This equipment is supplied with a 2 year warranty against defective workmanship

TELEPHONES LE LAS reserves the right to alter specifications without notice.

Weather proof IP66 telephone
for wall mounting, indoor or outdoor, for the
locale industrial and noisy

TLS 402E 2

Electrical Characteristics:

| | |
|-------------------------|------------------|
| Direct current supply: | 12 to 60 Vdc |
| Consumption: | < 40mA |
| Ringing voltage: | 35 – 80 Va |
| Dialling: | DTMF / decimal |
| Flashing/earth: | adjustable |
| Electronic Bell: | 90dB at 1 m. |
| Visual calling signal : | Non |
| LCD: | Non |
| Handset: | Non |
| Noise cancelling: | noise cancelling |
| circuit | |
| Hook: | magnetic |
| Conversation Mode: | By handset |

Others:

CCITT Q23

